

All Metal

allmetalroofing.com.au

All Metal Nailstrip - Data Sheet



ALL METAL ARCHITECTURAL PANELS

All Metal Nailstrip -Data Sheet

Used for wall or roof, All Metal Nailstrip offers a modern aesthetic appeal with a familiar ribbed profile design. The speed and ease of installation make this profile a popular choice.

Rib Height	25mm		38mm	
Standard Panel Width	290mm	490mm	265mm	465mm
Custom Panel Width	180mm - 490mm		180mm - 465mm	
Roof Pitch	Recommended min 7.5° (3.0° with sealant)			
Base Metal Thickness	0.55mm BMT			
Panel Length	Up to 8m (longer lengths available on request)			
Fixing Screws, typical	Steel 10 - 16 X 16 Wafer Head Tek Timber 10 - 12 X 25 Wafer Head type 17			
Finishes	Colorbond®, Colorbond® Matt, Colorbond® Metallic, Colorbond® Ultra, UniCote® Lux, Magnaflow®, Zinalume®, Galvanised, Aluminium Custom Colours are available, (MOQ and extended lead times apply)			

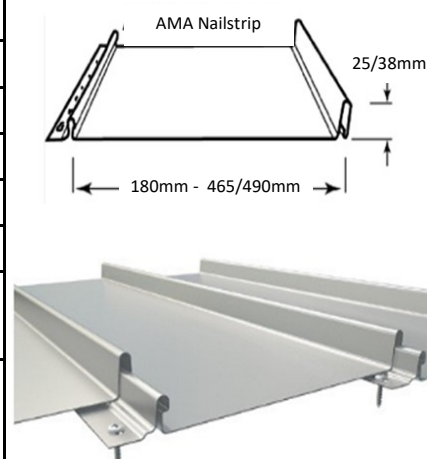

Installation

Panels can be installed vertically, horizontally or diagonally. Reduced installation times with no specialised tooling required means that the efficient direct screw fix installation process saves you money. All Metal Nailstrip is installed over a construction grade substrate. For roofing, 19mm ply is recommended. A breathable waterproof membrane (e.g. Enviroseal™ HTS) is placed in-between the All Metal Nailstrip and the substrate. For wall installations, All Metal Nailstrip panels can be fixed directly to battens. (for fixing aluminium, a separation tape can be used to prevent contact with dissimilar metals) Using the appropriate wafer head screw type, panels are fixed directly to the substrate through the slotted holes provided. Fixings should be spaced at maximum 600mm centres. After ensuring that the substrate is completely level, screw fix the first panel into position. The following panel is placed over the fixed panel and snapped into position by applying pressure to the rib.

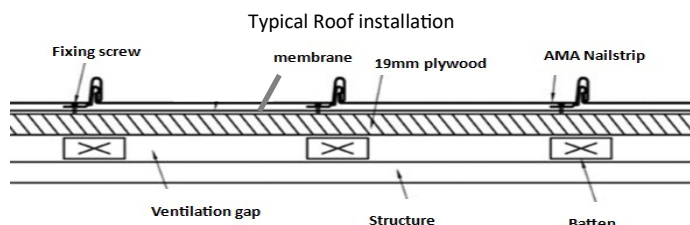
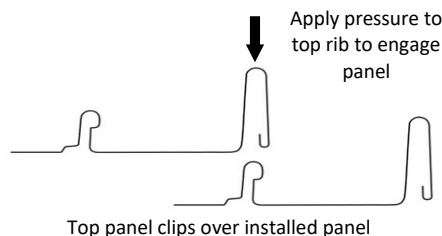

Finishes

Select the perfect finish for your project from our wide range of options. Samples and colour charts are available on request.

Accessories

All Metal can supply custom made starting and finishing panels. Factory folded internal and external corner tapered profiles can be made to suit your dimensions. We also provide everything you need to complete your installation including clips, specialised tools, angle cutting and made to order custom flashings.

Tolerance: All Metal will endeavour to produce finished products exactly as per the requested dimensions, please note that small variations can occur when folding or roll-forming products and as a result $\pm 4\text{mm}$ will be deemed to be within acceptable tolerance.

Fire Safety: All Metal Interlock is made using material that has been independently tested in accordance with AS 1530.3. The test measures, Ignitability Index, Spread of Flame Index, Heat Evolved Index and Smoke Developed Index and are deemed non-combustible as per the National Construction Code of Australia in accordance with clauses C1.19.(e).(v) and 3.7.1.1 (e)

Oil Canning: When using any light gauge flat metal products, a ripple effect may become visible in areas of an installation. The condition is normally related to thermal movement. It can be minimized by taking due care during the installation process and avoiding excessively large flat pans or high gloss finishes, Oil canning is not a defect of the finished product and does not adversely affect the warranty or durability of the material and as such does not warrant rejection of the finished product. For more information please refer to our Oil Canning information sheet.



Wetherill Park Unit 1, 171-175 Newton Road, Wetherill Park NSW 2164
Ph. 02 9756 3737 salesyd@allmetalaust.com.au

Northern Beaches 27 Ethel Avenue, Brookvale NSW 2100
Ph. 02 9756 3737 salesbro@allmetalaust.com.au

Mt Kuring-Gai Unit 2/6-10 Yatala Road, Mt Kuring-Gai NSW 2080
Ph. 0429 610 260 saleskur@allmetalaust.com.au

Tuggerah 8 Ace Cres, Tuggerah NSW 2259
Ph. 02 4352 3111 salestug@allmetalaust.com.au

Padstow 2 Watson Road Padstow NSW 2211
Ph. 02 9772 4400 salespad@allmetalaust.com.au

Newcastle 34 Huntington Drive, Thornton NSW 2322
Ph. 02 4062 0339 salesnew@allmetalaust.com.au